

Industrial machinery and heavy equipment

DiaCom

Industrial diaphragm maker achieves seamless transfer of tool design to manufacturing with Solid Edge

Products

Solid Edge, CAM Express

Business challenges

Deliver more complex diaphragms

Update products to match new market demands

Better align design and manufacturing

Keys to success

Move from 2D to 3D design

Use CAM software to program machines

Buy CAD, CAM tools from one source

Utilize dual support from partner and Siemens PLM Software

Results

30 percent faster new design

50 percent faster design changes

Seamless transfer of design intent to shop floor

DiaCom targets new markets demanding higher levels of technology for its complex molded diaphragms

Cutting-edge products, new geographic markets

About six years ago, industrial diaphragm manufacturer, DiaCom Corp. (DiaCom) initiated a shift in its approach to tool design and manufacturing. With a great customer reputation already in place, the time came to upgrade the company's technologies. The goal: expand into new markets.

The Amherst, New Hampshire-based company designs and manufactures innovative, cost-effective molded diaphragms critical to the operation of essential industrial systems and equipment. DiaCom not only produces diaphragms, but designs and builds the tooling to manufacture them. The company staffs design and tool departments as part of its business model.

The new technology shifts have allowed entry into new industries requiring more complex diaphragms as well as parallel markets. Those industry targets include aerospace, irrigation, automotive, oil, gas and medical customers. "We wanted to grow dynamically by offering more intricate, cutting-edge products and also expand into new geographic markets in China and Europe," says Mike Grywalski, manufacturing engineering manager at DiaCom.

"There's more technology demand from these new customers. They don't just need washers on a garden hose."

DiaCom customers operate in a different world, with more intricate design demands leaning heavily on parametric modeling to meet government and industry standards. Many of its longtime, established customers now require a similar technological ability to produce more advanced diaphragms.



DiaCom designs and manufactures homogeneous, fabric reinforced, insert bonded, Teflon bonded and fab air industrial diaphragms.

“On a recent complex mold project, Solid Edge modeling was 25 to 30 percent faster than traditional 2D design and was more accurate.”

Mike Grywalski
Manufacturing Engineering
Manager
DiaCom Corporation

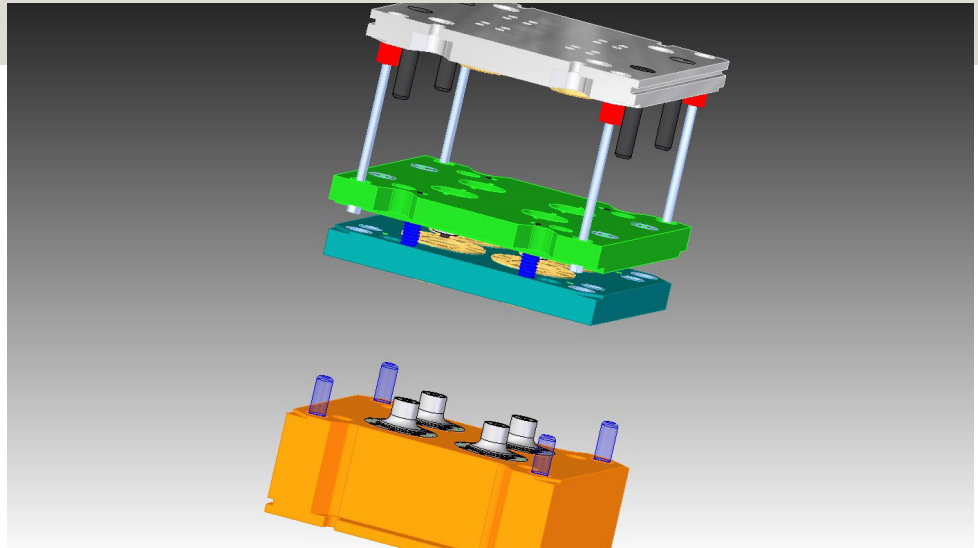

Die set that can form four diaphragms at once.

Design for manufacturing

Expansion required more advanced software technology. Customers were starting to come to DiaCom with 3D models to work from. The company was using 2D computer-aided design (CAD) software, producing “old-school” drawings that couldn’t fully define some products. DiaCom recognized the problem and decided to shift its design paradigm.

Grywalski’s shopfloor background helped him realize the need to bring the tool group on board with any CAD technology changes.

With many years of CAD and computer-aided manufacturing (CAM) software experience, he recalled compatibility, communication and technical support issues when using software from two different vendors.

“We wanted to bring the tooling group on board with our plans,” says Grywalski. “We wanted to implement CAD and CAM applications from one software company so we could get one-stop support.”

“Solid Edge and CAM Express have made a significant difference by improving our technical design and tool-build capabilities. They helped DiaCom provide complex products which would not have been as easily made several years ago.”

Mike Grywalski
Manufacturing Engineering Manager
DiaCom Corporation

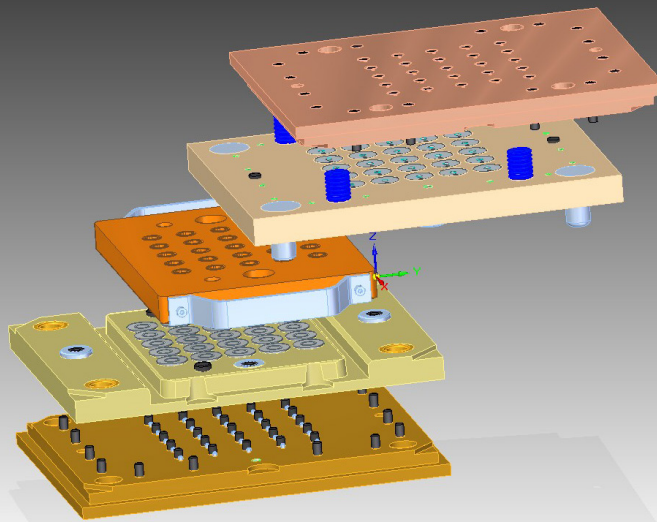

Exploded view of a die set capable of creating 20 diaphragms at once.

The company selected Solid Edge® software for 3D design and CAM Express software for manufacturing, both from product lifecycle management (PLM) specialist Siemens PLM Software. DiaCom relies on Siemens PLM Software solution partner LMGi for implementation, training and system support.

Move from 2D to 3D design for advanced parts

DiaCom evaluated multiple CAD systems including SOLIDWORKS® software, AutoCAD® software, Inventor® software, Pro/ENGINEER® software and Solid Edge. “While there were many software programs available, we selected Solid Edge because of available support from LMGi as well as from Siemens’ Global Technical Access Center organization. This support network paid off well as we initiated changes.” Besides the 24/7 support for both CAD and CAM questions, LMGi and Siemens PLM Software helped DiaCom identify postprocessors for its machine tools and solve other hardware/software interface challenges.

DiaCom determined that the Siemens PLM Software technology was impressive and pricing was competitive. “Solid Edge gave us

the technological capability to design the more complex parts required by existing customers as well as the other new customers we work with,” says Grywalski. “Today’s changes are often more challenging and can take longer. With 3D, it’s easier to make customer-requested design changes than it was with traditional 2D software.”

DiaCom has started to use the synchronous technology capability of Solid Edge, applying the simplicity of direct modeling with the control of parametric design. The company continues to evaluate synchronous technology as well as traditional ordered design. “In some cases, the ordered approach makes the most sense,” Grywalski says. “At other times, the synchronous approach seems best. Either way, we are seeing a reduction in design time and higher accuracy, both of which have a positive impact on manufacturing. For example, on a recent complex mold project, the use of Solid Edge modeling was 25 to 30 percent faster than traditional 2D design and was more accurate.”

“We wanted to bring the tooling group on board with our plans. We wanted to implement CAD and CAM applications from one software company so we could get one-stop support.”

Mike Grywalski
Manufacturing Engineering
Manager
DiaCom Corporation

Making modifications to existing diaphragm designs is quite common at DiaCom. By using synchronous technology instead of traditional history-based processes, DiaCom has experienced a reduction in revision time by up to 50 percent on recent design work.

DiaCom is designing programs to create automated part and tool models based on variable tables in Solid Edge. By applying new business engineering processes, these programs are being used by designers to accelerate design without sacrificing accuracy. Though this is in the early stages of development, the company has already experienced significant benefits with the new approach.

Solid Edge manufacturing

For its computer numerical control (CNC) programming tool, DiaCom selected CAM Express from Siemens PLM Software. DiaCom uses CAM Express to program its Okuma CNC lathe and Fadal CNC mill, among other pieces of equipment to machine the compression molds that are used to manufacture the diaphragms. DiaCom's tool room lead pioneered the use of CAM Express to program the machine tools. Additionally, the mill and lathe machine operators have been trained in the use of CAM Express to program the machine tools.

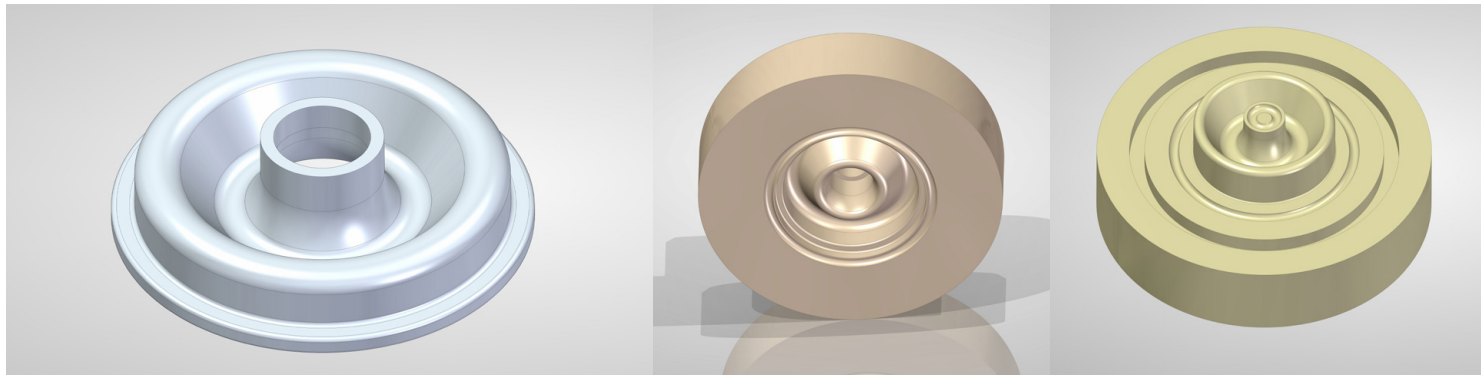

Upper and lower mold cavities (center and right), and the diaphragm they produce (left).

The combination of Solid Edge and CAM Express has provided “a seamless transfer of tool design communication between the design group and the shopfloor.”

Mike Grywalski
Manufacturing Engineering Manager
DiaCom Corporation

Solutions/Services

Solid Edge
www.siemens.com/solidedge
CAM Express
www.siemens.com/plm/camexpress

Customer's primary business

DiaCom Corporation designs and manufactures innovative, cost-effective molded diaphragms critical to the operation of essential industrial systems and equipment.
www.diacom.com

Customer location

Amherst, New Hampshire
United States

Partner

LMGi
www.TLMGi.com

"Solid Edge gave us the technological capability to design the more complex parts required by existing customers as well as the other new customers we work with."

Mike Grywalski
Manufacturing Engineering
Manager
DiaCom Corporation

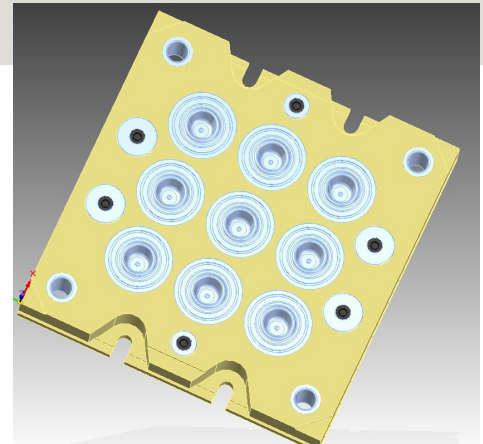
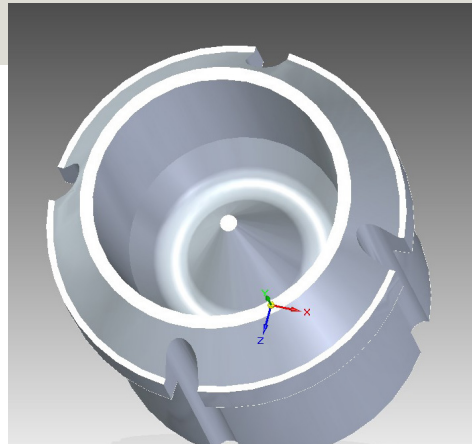

"With 3D CAD in place, we have been designing some pretty complex parts for various applications. Many customers prefer not to use traditional diaphragm designs," Grywalski says. The more sophisticated designs also required CAM Express 3-axis machine milling and turning programming capabilities.

The combination of Solid Edge and CAM Express has provided "a seamless transfer of tool design communication between our design group and the shop floor," says Grywalski. DiaCom evaluated four CAM packages and is pleased with its choice of CAM Express.

Other results from the technology upgrades and market expansion included building a new tooling complex and expansion of the design and tool manufacturing staff by about 60 percent.

"Solid Edge and CAM Express have made a significant difference by improving our technical design and tool-build capabilities," said Grywalski. "They helped DiaCom provide complex products, which would not have been as easily made several years ago."

Siemens PLM Software

Americas +1 314 264 8499
Europe +44 (0) 1276 413200
Asia-Pacific +852 2230 3308

© 2015 Siemens Product Lifecycle Management Software Inc. Siemens and the Siemens logo are registered trademarks of Siemens AG. D-Cubed, Femap, Fibersim, Geolus, GO PLM, I-deas, JT, NX, Parasolid, Solid Edge, Syncrofit, Teamcenter and Tecnomatix are trademarks or registered trademarks of Siemens Product Lifecycle Management Software Inc. or its subsidiaries in the United States and in other countries. AutoCAD and Inventor are registered trademarks of Autodesk Inc. Pro/ENGINEER is a registered trademark of PTC Inc. SOLIDWORKS is a registered trademark of Dassault Systèmes SOLIDWORKS Corporation. All other logos, trademarks, registered trademarks or service marks belong to their respective holders.

www.siemens.com/plm

52700-27 12/15 A